

M SERIES COIL PALLET NAILER

 Pallet Factory
Construction & Industry

AIR NAILER

MCN55

- Large piston with German workmanship
- Die cast aluminum body
- Light weight, well balanced
- Multi-directional exhaust
- Fires 15 degree wire-collated nails from 1"-2-1/4"
- Contact fire trigger
- Spare parts interchangeable with MAX
- Industrial grade super heavy duty coil nailer, Ideal for making pallets, packaging and crating

SPECIFICATIONS

Model No:MCN55	Dimension:283x131x270mm(11.14"x5.15"x10.62")
Weight:2.7Kg(5.94Lb)	Working Pressure:85-115Psi(5.8-8Bar)
Max.Pressure:120Psi(8.3Bar)	Load Capacity:300~350Pcs

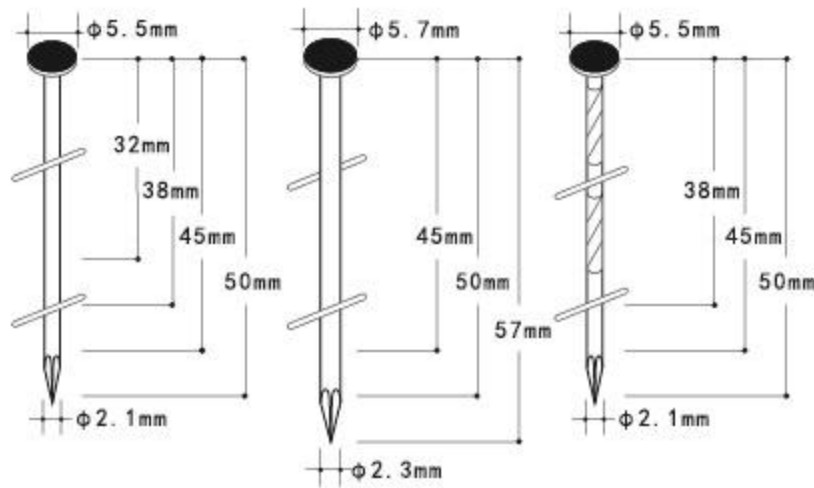
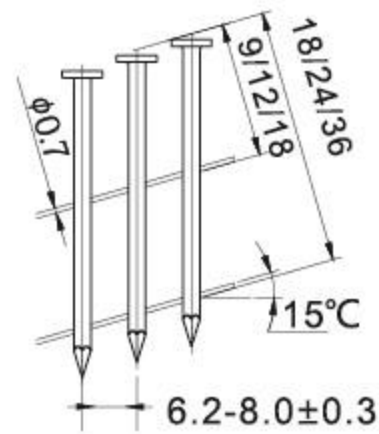

AIR NAILER

M SERIES COIL PALLET NAILER

 Pallet Factory
Construction & Industry

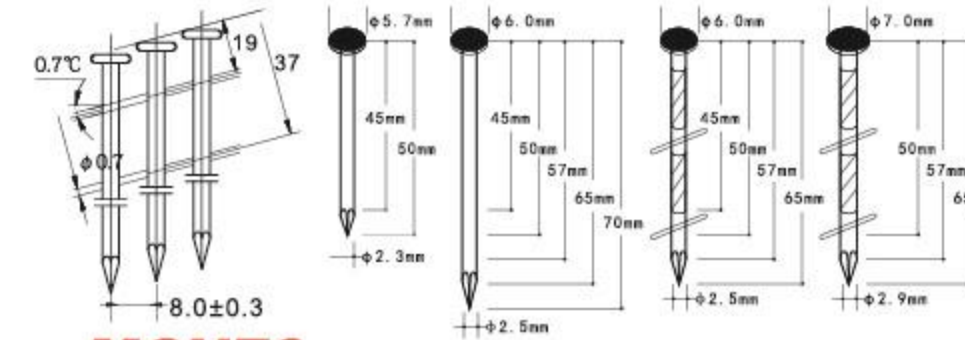

MCN70

SPECIFICATIONS

Model No.MCN70
Dimension:315x128x306mm(12.40"x5.03"x11.05")
Working Pressure:85-115Psi(5.8-8Bar)
Max.Pressure:120Psi(8.3Bar)
Weight:3.8Kg(8.36Lb)
Load Capacity:225-300Pcs

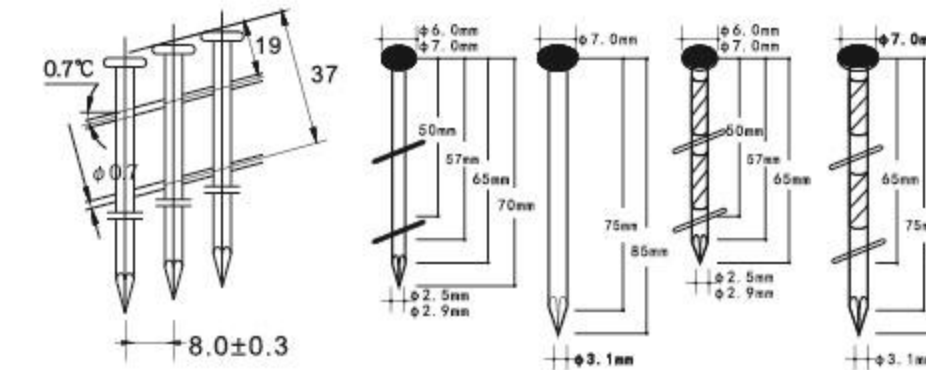

MCN80

SPECIFICATIONS

Model No.MCN80
Dimension:362x132x307mm(14.25"x5.19"x12.08")
Working Pressure:85-115Psi(5.8-8bar)
Max.Pressure:120Psi(8.3Bar)
Weight:4Kg(8.8Lb)
Load Capacity:300-350Pcs

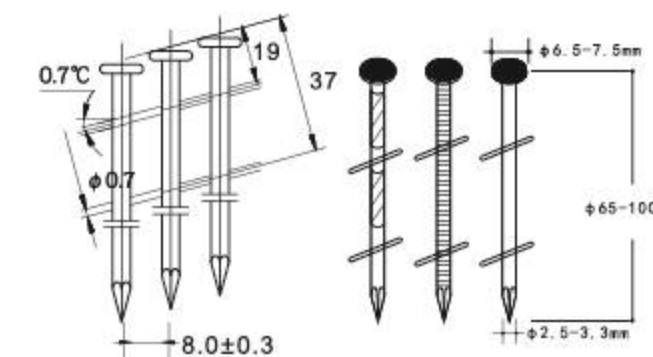

MCN100

SPECIFICATIONS

Model No.MCN100
Dimension:417x156x336mm(16.68"x6.14"x13.22")
Working Pressure:85-115Psi(5.8-8Bar)
Max.Pressure:120Psi(8.3Bar)
Weight:5.3Kg(11.6Lbs)
Load Capacity:150-300Pcs

